



PEERLESS

ROTARY SCREW COMPRESSORS

User Operation & Maintenance Manual

HQD30, HQD40, HQD50 & HQD75

VARIABLE SPEED ROTARY SCREW COMPRESSOR UNIT.



READ THIS MANUAL CAREFULLY BEFORE CARRYING OUT ANY OPERATIONS ON THE COMPRESSOR UNIT. FAILURE TO DO SO CAN RESULT IN SERIOUS INJURY OR DEATH. KEEP THIS MANUAL IN A SAFE LOCATION FOR FUTURE REFERENCE.

GENERAL INFORMATION

COMPANY	DATE PURCHASED
MODEL NO.	PURCHASED VIA
SERIAL NO.	DATE COMMISSIONED

TECHNICAL INFORMATION

MODEL		HQD30	HQD40	HQD50	HQD75
MODEL TYPE		BASEMOUNT	BASEMOUNT	BASEMOUNT	BASEMOUNT
FREE AIR DELIVERY	10 BAR	120 CFM 3396 LPM	180 CFM 5094 LPM	220 CFM 6226 LPM	350 CFM 9905 LPM
MOTOR	POWER KW / HP	22KW / 30HP	30KW / 40HP	37KW / 50HP	55KW / 75HP
	VOLTAGE / FREQUENCY	415V / 50HZ / 3P			
	TYPE	VARIABLE SPEED			
DRIVE TYPE		DIRECT DRIVEN			
AIR OUTLET		G1	G 1 1/2	G 1 1/2	G 2
SOUND LEVEL DB(A)		70 (+/- 2)	70 (+/- 2)	70 (+/- 2)	70 (+/- 2)
LUBRICANT (L)		15	20	20	35
AIR DISCHARGE TEMP (°C)		AMBIENT TEMPERATURE +15°C			
NET WEIGHT (KG)		590	940	940	1500
DIMENSIONS	LENGTH	1350	1420	1420	1750
	WIDTH	780	900	900	1100
	HEIGHT	1250	1425	1425	1425

Table of contents

1.	Introduction	4
2.	Company	4
3.	Our Products	4
3.1	Product Features	4
4.	Safety Information	5
4.1	Safety Information	5
4.2	Recognise Safety Alert Symbols	5
4.3	Operating	5
4.4	Service & Maintenance	6
4.5	Location of Safety Warning on Unit	7
5.	Installation	8
5.1	Receiving	8
5.2	Unpacking	8
5.3	Selecting a Location	8
5.4	Positioning the Air Compressor	8
5.5	Electrical Connection	9
5.6	Commissioning	9
5.6.1	Assembly & Installation	9
5.6.2	Operation	9
6.	LED Smart Screen Operation	10
6.1	Indicator Explanation	10
6.2	Status Display & Operation	10
6.3	Menu Options	11
6.4	Alarm Function	11
7.	Schedule Maintenance	12
7.1	Identification of Serviceable Parts	12
7.2	Weekly Maintenance	14
7.3	Hour Meter Service	15
7.4	Resetting Alarms	16
7.5	Auto Drain – Inspection & Testing (<i>IF FITTED</i>)	17
7.6	Regulator – Cleaning the Filter (<i>IF FITTED</i>)	18
8.	Trouble Shooting	19
9.	Electrical Circuit Diagram	20
10.	Certificate of Warranty	21
11.	Notes	22
12.	Service History	24
13.	Installation Checklist & Warranty Form	25
13.1	Manufacturer Checklist	25
13.2	Installer Checklist	25

1. Introduction

Thank you for purchasing this quality Rotary Screw Compressor that Peerless Products has supplied you. All Peerless Products are constructed using the highest quality materials and components. They are designed to the highest possible standards, therefore offering our customers endless hours of optimum performance.

2. The Company

Peerless Products are a family owned business which has been in operation for over 50+ Years, an Australian leader in the supply industrial air compressors and air related equipment based in Bendigo, Victoria.

We have a dealer network throughout Australia who are highly trained in our products along with our own teams located in each State that have high technical training on our complete range of industrial air compressors.

Peerless Products head office and manufacturing base is located in Bendigo (VIC).

3. Our Products

Peerless Products specialises in the design, engineering, manufacture, and marketing of Air Compressors equipment in these core categories:

- Manufacturing
- Automotive
- Farming & Agriculture
- Food processing
- Textile and Clothing
- Chemical industries
- Petrochemical industries
- Transportation
- Metal and Mining
- Electrical component manufactures
- Medicine and health
- Paper milling and printing
- and much more

3.1 Product Features

- Variable speed motor - save power and money
- Fail safe motor technology – will not start if phase reversed
- Oil / Air separator – high quality 2-3ppm
- Oversized Air End – not working as hard
- Ease of servicing yourself – competitive spare parts pricing
- Intelligent fully automated operation / monitoring touch screen controller

4. Safety Information

4.1 Safety Instructions

For your personal safety, and that of others working around you please read, understand, and follow thoroughly all safety instructions included in this manual and on the Compressor.

- BEFORE removing any panels for maintenance disconnect the electrical power supply.
- Review all applicable OSH (Occupational Safety & Health) regulations.
- Learn how to operate the Compressor and use the controls properly.
- Do not allow untrained personnel to operate the machine.
- Ensure that the Compressor is maintained as per service manual instructions.
- Do not allow any unauthorised modifications to the machine.

4.2 Recognise Safety Alert Symbols

The safety alert symbol precedes Warning and Caution notes throughout this manual. To prevent personal injury or damage to the machine these alerts must be strictly adhered too.

	Warning	Alerts to a potentially hazardous situation that if not avoided CAN result in death, serious injury.
---	----------------	---

	Caution	Alerts to a potentially hazardous situation that if not avoided MAY result in injury or equipment damage.
---	----------------	--

4.3 Operating

	Warning	Compressors are intended for indoor operation only; do not operate outside unless suitably protected by a weatherproof enclosure. This appliance is not suitable for installation in an area where a water jet could be used.
---	----------------	---

	Caution	This appliance is not intended for use by persons (including children) with reduced physical, sensory or mental capabilities, or lack of experience and knowledge, unless they have been given supervision or instruction concerning use of the appliance by a person responsible for their safety.
---	----------------	---

4.4 Service & Maintenance



Caution

Installation of Compressor and service work should only be performed by fully trained & certified Electrical, Plumbing, & Technicians.



Warning

ALL WIRING AND PLUMBING MUST CONFORM TO LOCAL AND NATIONAL CODES.



Warning

COMPRESSOR MUST BE ISOLATED FROM ELECTRICAL SUPPLY BEFORE COMMENCING ANY SERVICE OR MAINTENANCE WORK.



Warning

HOT SURFACE. DO NOT TOUCH.
WAIT FOR COMPRESSOR TO COOL DOWN PRIOR TO ANY SERVICE WORK.

4.5 Location of Safety Warnings on Unit

Warning labels have been applied for safety purposes and must not be removed or spoiled for any reason.

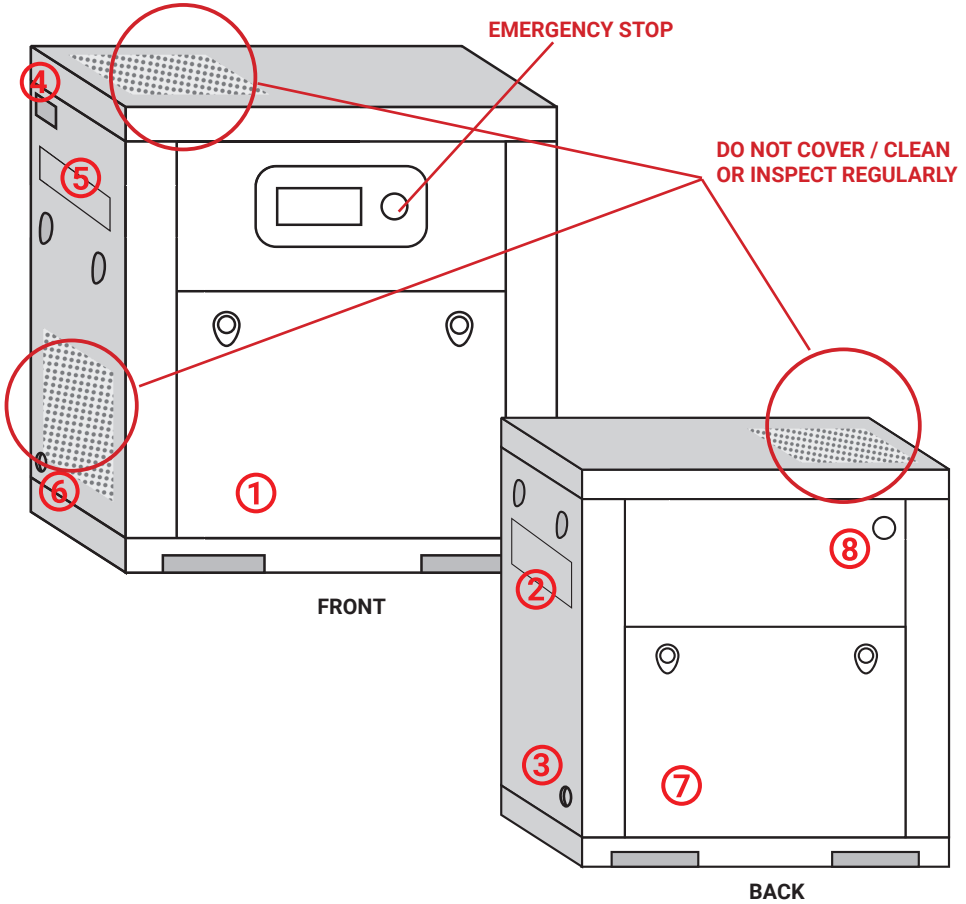

- 1) **WARNING**
Keep hands away from moving parts
- 2) **OPERATING INSTRUCTIONS**
MAINTENANCE SCHEDULE
- 3) **DRAIN PORT**
- 4) **IDENTIFICATION PLATE**
- 5) **WARNING ELECTRIC SHOCK**

- 6) **POWER SUPPLY PORT**
 - 7) **HIGH TEMPERATURE**
 - 8) **EXHAUST OUTLET**
- WARNING MOVING PARTS**
WARNING READ MANUAL
DANGER HIGH TEMPERATURE
DANGER NOT BREATHABLE AIR

5 Installation

5.1 Receiving

Each unit is completely tested under operating conditions and thoroughly inspected before shipment. At time of shipment, the carrier accepts the unit and any claim for damage(s) must be made with the carrier. Upon receiving units from the delivering carrier, carefully inspect shipping crate for visible indication(s) of damage. If damage exists, have carrier note damage on bill of landing and file a claim with the carrier.

5.2 Unpacking

Carefully unpack the Peerless Rotary Screw Compressor.

Inspect unit for concealed damage and if evident, notify delivering carrier and file a claim against the carrier.

5.3 Selecting a Location



Warning

Compressors are intended for indoor operation only; do not operate outside unless suitably protected by a weatherproof enclosure.

This appliance is not suitable for installation in an area where there is no ventilation, 1 meter clearance around Air Compressor on all sides required for air flow and servicing.



Caution

The Compressor is only to be installed in locations where its use and maintenance is restricted to trained personnel.

- The Peerless Compressor should be in a well-ventilated, firm, level location, access to electrical supply point (within 1m) and with easy access for servicing.
- Consideration needs to be given to compressor tank water drainage, both access and fall.
- Ensure sufficient clearance around Compressor to allow good fresh air circulation.
- Installation should only be performed by a qualified and competent technician.
- **Do not place machine in direct sunlight.**

5.4 Positioning the Air Compressor

- Place on a flat, stable level surface.
- Ensure the Air Compressor is secured to the ground using the mounting points.



Caution

Compressor operational weight is 220Kg-450Kg; ensure that all supporting structures are certified for this load. Supporting structure must be securely fixed to floor.

5.5 Electrical Connection

- It is recommended that the Compressor is connected to a separate 415V electrical supply, protected by an appropriate D Curve circuit breaker.
- Check the nameplate on the Compressor for the electrical supply requirements and make sure that the supply voltage is the same.
- Check to make sure the electrical are in proper condition and there is a grounded lead.
- Connect compressor to power with care. Wiring must be the same as in wiring diagram supplied.
- The service of a licensed electrician may be required to ensure the installation is in accordance with the local codes and regulations.

5.6 Commissioning

5.6.1 Assembly & Installation

- When placing the Air Compressor in its fixed location place high density rubber matt under feet (8-15mm)
- 1.5 meter minimum clearance around (including above) the Air Compressor for air flow and servicing requirements.
- Install drainage hose to the auto drain outlet. (If dryer included)
- Connect the airline to outlet of the Compressor (Regulate if using air tools). Can be beneficial to include a bypass valve for ease of servicing.
- Connect Compressor power supply with isolating switch.

5.6.2 Operation

- Before turning on compressor first do preliminary checks.
 - Check Oil Level
 - Check all Panels are in their correct position
 - If Compressor does not turn on it has been wired incorrectly, motor will only start in correct rotation.
 - Using the MAM6070 control system press the  Start / Stop button, this will start the compressor.
 - Once the compressor has reached it's set pressure it will go into unload. Please record times in the **WARRANTY FORM** located in the back of this manual.
 - The Dryer (if dryer included) is fitted with an automatic drain solenoid valve with an electronic timer. This will be set ex factory to a 5 second burst every 10 minutes.
 - *Depending on the environment and location of the compressor this setting may need to be adjusted. Call Peerless for assistance in this matter.*
 - *Press the "TEST" button on the auto drain to discharge condensate manually and check the valve operation*

6. LED Smart Screen Operation

6.1 Indicator Explanation

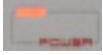

Power: Indicator is alight when controller is powered on.

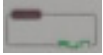

Run: Indicator is alight when motor is running.

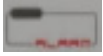

Alarm: Indicator is blinking when controller is alarming and running.
Indicator is alight when compressor is alarming and stopped.
Indicator is off after error is cleared and reset.



6.2 Status Display & Operation

The display screen will show as below after initially turning power on while the unit loads.



After a few seconds the menu will switch as below

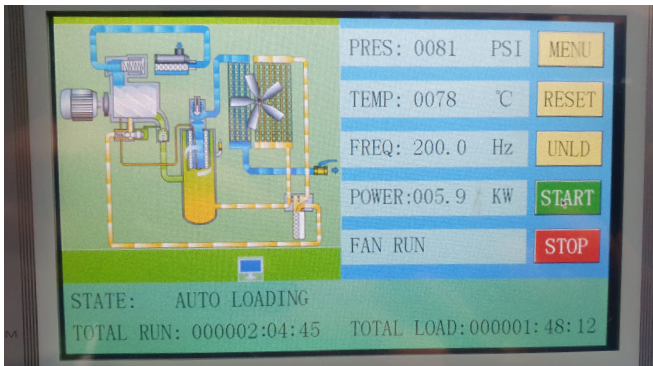

To prevent interference, it will take 0.2s to take an effect after pressing start/stop button



Auto restart function activated



Computer connected



Remote function activated



Network function activated

The below menu can be accessed through the  icon.



6.3 Menu Options

- Run parameter will show you a log of total run times
- User Parameter will allow you to customise your compressor settings to best suit your air needs. For assistance please contact Peerless Products to speak with a specialist.
- Maintenance Parameter is used for servicing your compressor. In this screen you will be able to reset alarms and set the lifespan of servicable parts. See scheduled maintenance for step by step information.
- Fault Record will record a history of fault entries up to 100.

6.4 Alarm Function

Air filter alarm

- The monitor will display AIR TIME END at the end of the air filter life span

Oil filter alarm

- The monitor will display OIL LIFE END at the end of the oil filter life span

Oil & Air Separator alarm

- The monitor will display O/A TIME END at the end of the O/A Separator life span

Lubricating alarm

- The monitor will display LUBE TIME END at the end of the compressor oil life span

Grease alarm

- The monitor will display GREASE LIFE END at the end of the set life span

Discharge high temperature alarm

- The text displays DISC T HIGH when DISC T is higher than ALARM DISC T set in FACTORY PARAMETER

7. Scheduled Maintenance



Caution

Installation of Compressor and service work should only be performed by fully trained Technicians.



Warning

The Compressor must not be cleaned by a water jet



Warning

COMPRESSOR MUST BE ISOLATED FROM ELECTRICAL SUPPLY BEFORE COMMENCING ANY SERVICE OR MAINTENANCE WORK.

7.1 Identification of Serviceable Parts

- Images based on HQD10

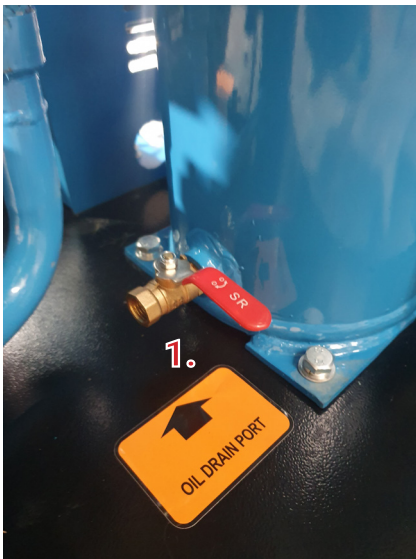

1. Oil Drain Tap



2. Oil Filter



3. Air Filter



4. Oil & Air Separator
(INSIDE SUMP)

5. Oil fill point



6. Oil sight glass
Check oil level daily

7.2 Weekly Maintenance

- Check the condition of the Water Trap Regulator & Filtration - If any are inline. Make sure the brass element is clean and not containing sludge. If dirty, unplug the compressor, vent all air, then remove and clean with hot water.
- Check for any air leaks - when the compressor is idle there should be no air leaks.
- Check for any oil leaks.
- Maintain and clean cabinet from any excessive dust.
- Drain the Air Tank (if fitted), but first turn the Air Compressor OFF by;
 - Press the  start / stop button on the control panel (roughly a 20 - 30 second stop delay.)
 - Drain the air tank through the drain cock or valve located on the under side of the air receiver. If there is an excessive amount the Auto Drain (if fitted) will need to be adjusted to a more regular drain time or otherwise manually drain your tank on a more regular basis. Auto drain kits can be purchased through Peerless Products and retro fitted.
- Test the Auto Drain (if fitted) Refer to 7.5
 - Press the "TEST" button on the auto drain which will release a burst of air and the stop. If this does not work release air from the air receiver until the air compressor cycles and see if the Auto drain turns ON and OFF - if the Auto Drain does this it is OK.

Maintenance Part	To Be Done	Replacement Times	Daily Check
Leaks	Examine		✓
Oil Levels	Examine		✓
Oil Tank	Examine		✓
Oil Temp.	Examine		✓
Air Filter Element	Clean	500 Hours then 1000 Hours	✓
Oil / Air Cooler	Clean	500 Hours	
Grease	Change	500 Hours then 1000 Hours	
Oil Filter	Change	500 Hours then 2000 Hours	
Oil Air Separator	Change	2000 Hours	
Motor	Examine / Grease	3000 Hours	

7.3 Hour Meter Service

Turn the Air Compressor off by pushing the  start / stop button on the control panel (15-20 second delay). Then proceed to do your servicing of the Screw Compressor.

First 500 Hours

- Change Oil
- Change Oil Filter
- Change Air Intake Filter (Replace every 500Hrs if in a dirty environment or 1000Hrs in normal conditions)
- Blow out radiator from inside out – not direct high-pressure air as this can damage fins

2000 Hour Service

- Change Oil
- Change Oil Filter
- Change Oil / Air Separator
- Change Air Intake Filter (Replace every 500Hrs if in a dirty environment or 1000Hrs in normal conditions)
- Blow out radiator from inside out – not direct high-pressure air as this can damage fins

4000 Hour Service

- Change Oil
- Change Oil Filter
- Change Oil / Air Separator
- Change Air Intake Filter (Replace every 500Hrs if in a dirty environment or 1000Hrs in normal conditions)
- Blow out radiator from inside out – not direct high-pressure air as this can damage fins
- Grease Rear and front motor bearings

After this period, Service hours repeat at the 2000 Hour and 4000 Hour cycle.

7.4 Resetting Alarms

Once you have completed your service and replaced the required parts you'll need to reset the computer.

500H Service Alarms

With power to the unit;

- Touch the screen
- Select "Main Para"
- You will see a list of run times, max times and there corresponding times in hours
- Click on the numbers next to "oil run time" this will prompt you for a password, enter **5588**.
- Then reset this time back to zero then hit enter
- Do the same for "air run time" and "lube run time" as all three of these alarms will be active at the 500 hour mark
- Once they have been adjusted the alarm will cease, while in the menu still though change the following times as well
- "air max time" = 750 hours (this will be changed to 1000 at the next service)
- "oil max time" = 2000 hours
- "lube max time" = 2000 hours
- Once changed return all the way to the main screen and the altercations are complete

The first 500 hour service point as the unit warns you it is time for an air filter, oil filter and oil change, these alarms are changed to warn you at the machines 1,250th hour it's time for a new air filter. The next alarm triggers at the machines 2,000th hour warning you it's time for its first major service.

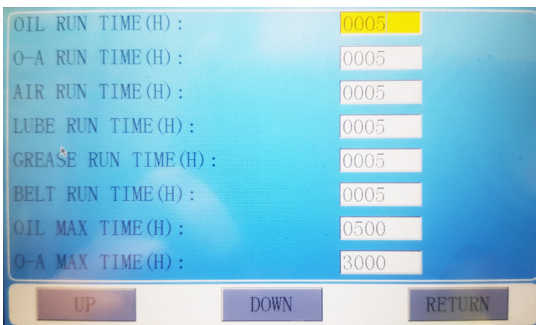

Follow these instructions to reset alarms for future services, the only changes being the max time hours.

7.5 Auto drain - Inspection & Testing (if fitted)

The compressor is fitted with an automatic drain solenoid valve with an electronic timer. This removes condensate from the air receiver. The default factory is a 5 second burst every 10 minutes however it is important to monitor moisture in your air receiver and alter the timer to suit your specific needs.

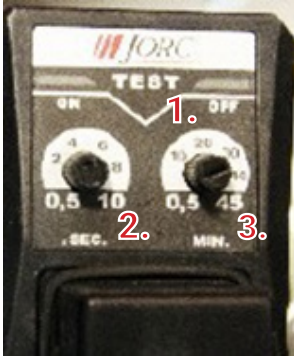

1. Test Button: Push to activate.

If functioning OK, the Light will activate above the ON label and a burst of air will release, then stop.

2. Left Dial: Discharge Time (seconds)

Length of time moisture is drain from the tank at each interval.

Factory Setting: 5 seconds

3. Right dial: Interval Time (minutes)

Discharge time interval while the compressor is running.

Factory Set: 10 minutes



4. On Light: automatic drain is activated and should be dispensing air.



5. Off Light: automatic drain is powered, but is not dispensing air.

7.6 Regulator - Cleaning the filter (if fitted)

The Regulator is used to set your working pressure, this is also use to minimise the amount of water and impurities in the air supply.

NOTE: Electrically isolated & vent all air in the system before removing & washing the water trap & filter.



Adjust regulated pressure setting by lifting & turning the black knob:

- **RIGHT** to **INCREASE** supply pressure.
- **LEFT** to **DECREASE** supply pressure.

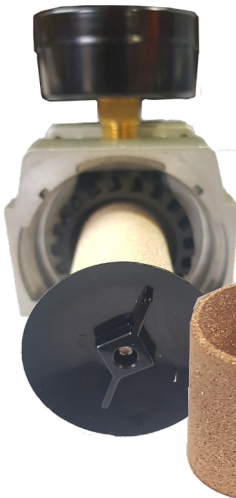

To clean the filter regulator brass cartridge first remove the bowl. Depending on the model regulator there may be a shield and a clear bowl or just a metal bowl. The brass cartridge will be held in place by a screw as pictured below.

The brass cartridge can be washed under hot running water.



8. Trouble Shooting

Problem	Possible Cause(s)	Corrective Action
Compressor will not run	<ol style="list-style-type: none"> 1. No Electrical Power 2. Blown Fuse 3. Breaker Open 4. Phase is reversed - alarm on screen 	<ol style="list-style-type: none"> 1. Plugged in? Check fuse/ breaker 2. Replace blown fuse 3. Reset determining why problem happened 4. Re-wire correctly
Air Compressor shuts down	<ol style="list-style-type: none"> 1. Low oil level 2. Over Heating 3. Emergency stop has been pushed 	<ol style="list-style-type: none"> 1. Check oil level and fill / service 2. 110 degrees will shut down, let cool and vent, extra ventilation may be required in hot areas 3. Check why its been pushed and reset when safe to do so
Circuit breaker trips repeatedly CAUTION! Never use an extension lead with this product	<ol style="list-style-type: none"> 1. Incorrect size fuse, circuit overloaded 	<ol style="list-style-type: none"> 1. Check the proper fuse. Use D Curve fuse. Disconnect from other electrical appliances from circuit or operate compressor on its own circuit
Tank pressure drops when compressor shuts off	<ol style="list-style-type: none"> 1. Loose connection (fittings, tubing, etc.) 2. Open draincock 	<ol style="list-style-type: none"> 1. Check for air leaks. Use sealing tape on all leaking connections 2. Tighten/Close drain cock
Excessive moisture in discharge air	<ol style="list-style-type: none"> 1. Excessive water in tank 2. High humidity 3. Clogged intake filter 	<ol style="list-style-type: none"> 1. Drain receiver and check the dryer is draining correctly - test auto drain & increase auto drain settings if necessary 2. Move compressor to area of less humidity; use inline filter Clean and replace filter
Compressor vibrates	<ol style="list-style-type: none"> 1. Loose mounting bolts 2. Rubber tank feet worn / missing 	<ol style="list-style-type: none"> 1. Tighten 2. Replace
Air output lower than normal	<ol style="list-style-type: none"> 1. Open draincock 2. Intake filter dirty 3. Connection leaking 	<ol style="list-style-type: none"> 1. Tighten draincock 2. Clean or replace intake filter 3. Tighten all connections

9. Electrical Circuit Diagram

Wiring (Internal Box)	L1	L2	L3
Australia	Red	White	Blue
International / EU	Yellow	Green	Red

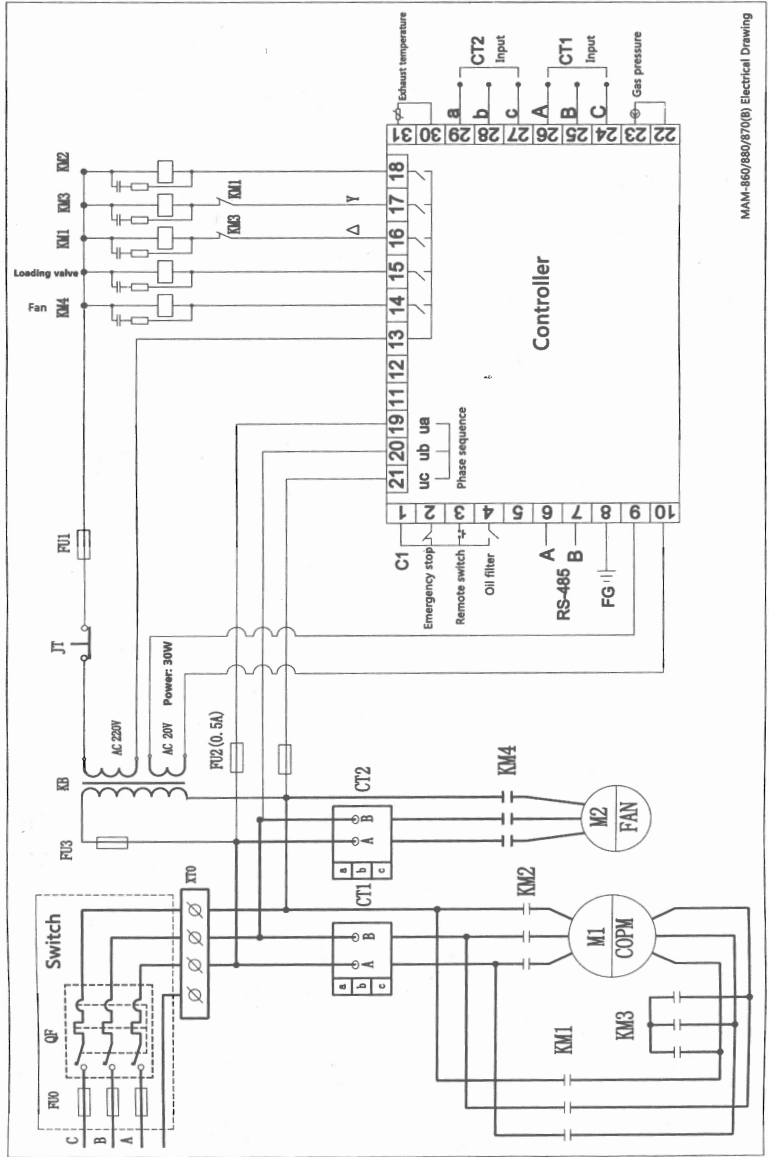

MAM-860/880/870(B) Electrical Drawing

10. Certificate of Warranty

It is the policy of Peerless Products to provide to its current customers, warranty for all equipment supplied and installation work performed within a specified period.

Parts and Equipment

Peerless Products provides a warranty period of twelve (12) months from the date of original invoice for all manufactured parts and the associated labour. Repair or replace of defective parts will be at the sole discretion of Peerless Products.

Changeover parts will be invoiced to the customer at the customers normal purchase cost and upon return of the warranty item and validation of the claim, the invoice will be credited.

Installations

Peerless Products provides a warranty period of twelve (12) months from the date of final invoice for workmanship after the completion of any installation work.

Labour

Peerless Products will not normally cover any labour costs associated with a warranty claim. Subject to the approval of the Divisional Sales Manager, Peerless Products may choose to reimburse the customer for some or all labour costs associated with a warranty claim. Any claim for labour costs must be authorized by Peerless Products prior to the work being undertaken.

Exclusions

Peerless Products will not accept any liability or cost associated with any consequential losses, or loss of profit or damage to property as a result of faulty product.

Warranty shall not apply:

- a) If in the opinion of Peerless Products, the equipment has been used in a situation the equipment has not been designed for;
- b) If in the opinion of Peerless Products, the equipment has been subject to abuse, negligence or accident;
- c) If connected to improper, inadequate or faulty power, water or drainage service or operated using incorrect, insufficient or contaminated lubricants, coolants, refrigerants or additives;
- d) Where the product is installed, maintained or operated otherwise than in accordance with the instructions supplied by Peerless Products;
- e) Where the product has been damaged by foreign objects;
- f) Where the product has been serviced, repaired, altered or moved otherwise than by Peerless Products or its nominees or using other than Peerless approved replacement parts.

To obtain full details of your warranty and approved service agency, please contact your dealer/supplier, or the nearest Peerless Products Agent.

Peerless Products TEL: 03 5434 4200 FAX: 03 5442 2129

11. Notes

12. Service History

500 Hour Service

Service Agent: _____ Service Agent Number: _____

Date of service ____ / ____ / ____ Signature: _____

Notes at time of Service _____

2000 Hour Service

Service Agent: _____ Service Agent Number: _____

Date of service ____ / ____ / ____ Signature: _____

Notes at time of Service _____

4000 Hour Service

Service Agent: _____ Service Agent Number: _____

Date of service ____ / ____ / ____ Signature: _____

Notes at time of Service _____

6000 Hour Service (Same as 2000 Hour)

Service Agent: _____ Service Agent Number: _____

Date of service ____ / ____ / ____ Signature: _____

Notes at time of Service _____

8000 Hour Service (Same as 4000 Hour)

Service Agent: _____ Service Agent Number: _____

Date of service ____ / ____ / ____ Signature: _____

Notes at time of Service _____

13. Installation Checklist & Warranty Form

13.1 Manufacturer Checklist

Model No.:	Tank Serial No.:	Auto Drain Function Set:	Check Elec Wiring:	Check Oil Safety Valve:	Safety Valve Serial No.: <i>(if applicable)</i>	Comp. Cycle Time: <i>(mins)</i>	Date Checked:	Checked By:

13.2 Installer Checklist

Check Supply Point:	No Air Leaks:	Auto Drain Function Set:	Time until tank full pressure:	System time to full pressure:	Check Safety Valve:	Mounted correctly: <i>(rubber mats under feet)</i>	Installation Date:
Voltage: L1 L2 L3 Protection Type:		Burst time: Time Delay:					

Installed At:	Installation Company:
Installation Address:	Installer Name:
	Contact Phone Number:
	Signature:

MANUFACTURERS WARRANTY REGISTRATION

Once the Compressor has been installed please send this form back completed along with proof of purchase and a photo of the installation to: sales@peerlessproducts.com.au
Failure to register your Peerless Compressor will result in all warranty claims being denied.

Registration must be completed within 7 days of installation, any problems with Installation must be advised to Peerless Products Service Department Immediately.
Peerless Products will not accept any warranty claims unless they have been authorised prior through the Peerless Products Service Department.



PHONE **03 5434 4200** | FAX **03 5442 2129**
EMAIL **SALES@PEERLESSPRODUCTS.COM.AU**

HQD30, HQD40, HQD50 & HQD75 VARIABLE SPEED SCREW COMPRESSOR

- 2023-